

This high thrust MJP Ultrajet is specifically introduced for Seismic, Landing Craft, Cargo carrying, Commercial and Military Tow vessel applications, where high static thrust is a prerequisite.

## MJP Ultrajet 305HT

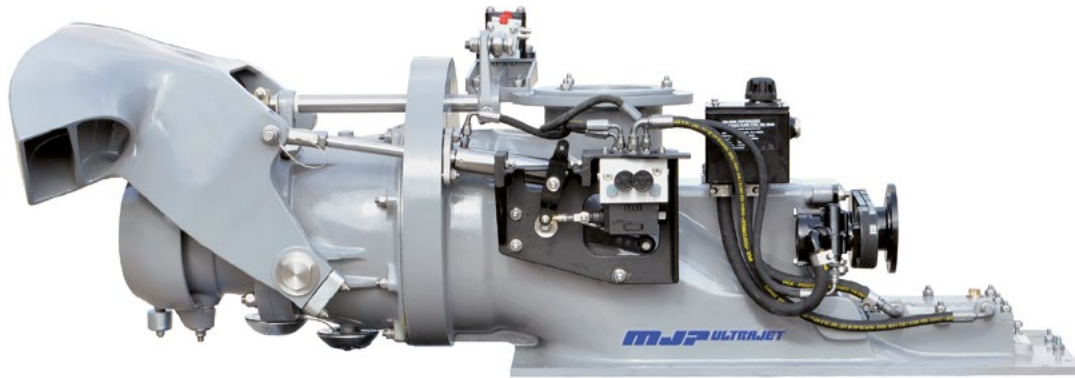

Lloyds ISO9001 approved

### Features & Benefits

- 10 % higher static thrust than the standard MJP Ultrajet 305.
- Superior static thrust to wet weight ratio of any production waterjet currently available
- Developed specifically to provide increased static thrust for Bridge Erection, Seismic Surveying and Towing purposes
- Uses same high quality production methods as the MJP Ultrajet 305 to allow volume manufacture at competitive prices
- Superior manoeuvrability. Ability to accelerate quickly, reverse, stop, rotate, hold station and move sideways
- Light weight and compact design with a variety of on jet and remote mounted hydraulic control systems
- Installation dimensions enable exchange with standard MJP Ultrajet 305 with minimal modifications

### Description

The MJP Ultrajet 305HT (High Thrust) is a derivative of the MJP Ultrajet 305 which has been in service world-wide for over 10 years. The MJP Ultrajet 305HT has the same major installation dimensions and can be installed into an identical space envelope. Incorporating an efficient and robust axial flow pump, reverse and steering controls, it has many of the same design features as used in the current MJP Ultrajet range.

The proven 4 and 5 bladed impeller design is less susceptible to mechanical damage than multi bladed designs. To achieve superior thrust, design improvements have been made to the intake and impeller of the MJP Ultrajet 305HT.

This high thrust unit was specifically introduced into the MJP Ultrajet range for Bridge Erection, Seismic Surveying and Towing applications where high static thrust is a prerequisite.

### Planing Craft

Maximum input power 298 kW (400 HP)

Single jet up to 9 tonnes (19,836 lb.)

Twin jets up to 20 tonnes (44,080 lb.)

Triple jets up to 32 tonnes (70,528 lb.)

### Displacement Craft

Maximum input power 261 kW (350 HP)

Single jet up to 15 tonnes (33,060 lb.)

Twin jets up to 33 tonnes (72,732 lb.)

Triple jets up to 55 tonnes (121,220 lb.)

Note: The displacement figures can often be exceeded on good hull shapes.

# MJP ULTRAJET

## MJP Ultrajet 305HT

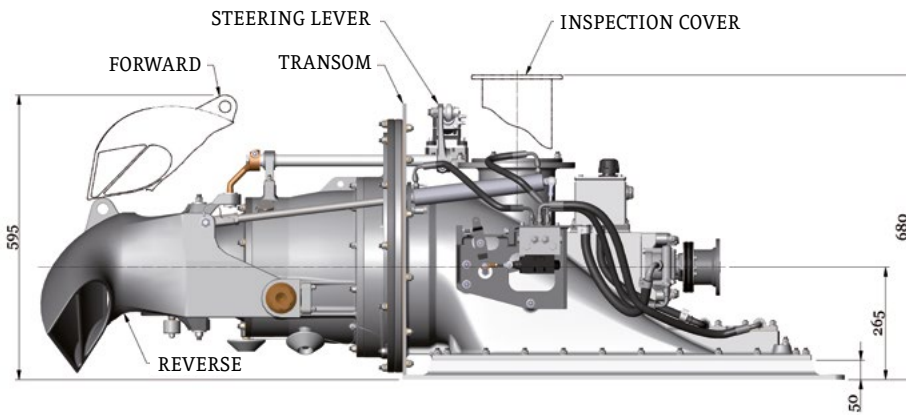

OUTBOARD VIEW OF MJP ULTRAJET UNIT

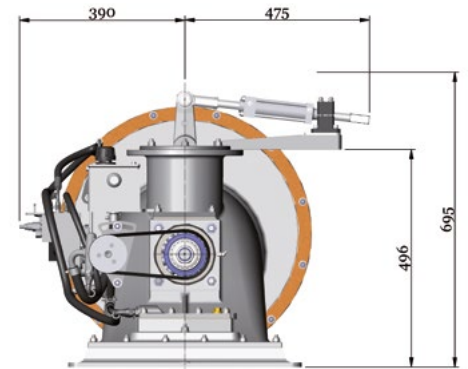
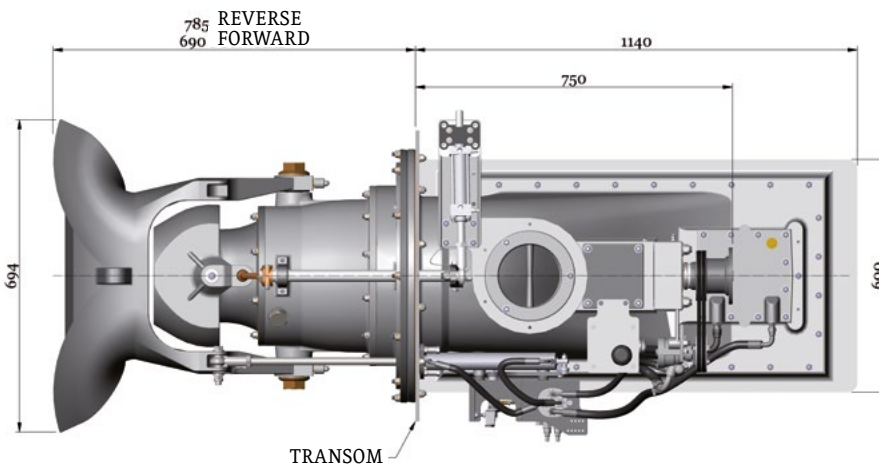

INBOARD VIEW OF MJP ULTRAJET UNIT

### Typical Specifications:

1. Unit weight 205 kg (452 lb.) dry (Base jet without controls) or 243 kg (534 lb.) including entrained water.
2. If a detailed weight analysis is required please contact our Technical Department.

We have a policy of continuous improvement in design. Specifications may, therefore, be changed without notice. When considering applications for this equipment it is recommended that our Technical Sales Department is consulted.

Marine Jet Power AB  
Hansellisgatan 6  
SE 754 50 Uppsala  
Sweden  
Tel: +46 (0)10 165 10 00

Marine Jet Power Inc.  
6740 Commerce Court Drive  
Blacklick, OH 43004-9200  
USA  
Tel: +1 (614) 759 90 00

Marine Jet Power Korea Co. Ltd  
#C-809  
Centumdong-Ro 123  
Haeundae-Gu  
Busan 48050 Korea